



*Instrumentation designed
with the user in mind*

Instruction Manual Princo Model L3515

**Presence/ Absence Detector
with NULL-KOTE™**

Rev 4, 3 Nov 08



PRINCO INSTRUMENTS INC., 1020 INDUSTRIAL BLVD., SOUTHAMPTON, PA 18966

PHONE: 800-221-9237 or 215-355-1500

FAX: 215-355-7766

WEB SITE: www.princoinstruments.com

E-Mail: info@princoinstruments.com

Table of Contents

1	DESCRIPTION	1
1.1	General Description	1
1.2	Functional Description.....	1
1.2.1	Basic Features	1
1.3	Sensor Flange Description	2
2	SPECIFICATIONS.....	4
2.1	L3515 Presence Absence Detector	4
2.2	L600 Series Sensor Flanges	4
3	INSTALLATION	6
3.1	Inspection.....	6
3.2	Mounting.....	6
3.2.1	Partial-ring Flange (L632, L642, L652, L662) Location	6
3.2.2	Full-ring Flange (L631, L641, L651, L661) Location	6
3.2.3	Full-faced Gaskets & Flanges	6
3.2.4	L3515 Controller Mounting.....	7
3.2.5	Spring-loaded Pin	8
3.2.6	Grounding	8
3.2.7	Ground Continuity Test	8
3.3	Electrical Connections	9
3.4	Installation in Hazardous Areas	9
4	ADJUSTMENTS AND OPERATION	11
4.1	Initial Checkout	11
4.2	Calibration	11
4.2.1	Adjustment Procedure - Conductive Process Materials	11
4.2.2	Adjustment Procedure – Non-conductive (Insulating) Process Materials	12
4.3	Alarm Action	13
4.4	Delay Operations and Adjustments.....	13
4.5	Start Pump Push-button	13
5	EQUIPMENT SERVICE	15
5.1	Trouble-Shooting Guide	15
5.1.1	Basic Electronic Checks	15
5.1.2	Adjustment Problems.....	15
5.2	Getting Help.....	15
5.3	Warranty Statement	16

Illustrations

Figure 1-1. Typical L631 and L632 Sensor Flanges.....	3
.Figure 1-2. L3515 Outline Drawing and Dimensions.....	3
Figure 3-1. Correct Horizontal Installation (Horizontal View).....	7
Figure 3-2. Questionable Horizontal Installation (Horizontal View).....	7
Figure 3-3. Correct Vertical Installation (Horizontal View).....	7
Figure 3-4. Questionable Vertical Installation (Horizontal View).....	7
Figure 3-5. Correct Horizontal Installation (Vertical View).....	7
Figure 3-6. Questionable Horizontal Installation (Vertical View).....	7
Figure 3-7. Spring-loaded Pin.....	8
Figure 3-8. L3515 Installation and Ground Checks.....	8
Figure 3-9. Electrical Connections (115Vac & 230Vac Units)	10
Figure 3-10. Electrical Connections (24Vdc Unit)	10
Figure 4-1. L3515 Adjustment and Indicator Locations	11
Figure 4-2. Conductive Process Calibration Procedure	12
Figure 4-3. Non-Conductive Process Calibration Procedure	14

1 Description

1.1 General Description

The Princo Model L3515 Presence/Absence Detector is an adjustable, RF impedance-sensing device which, when connected to any Princo L600 Series Sensor Flange, can be used to detect the presence or absence of process material within a pipeline. The L3515 unit, with Sensor Flange, is used for obstruction-less presence/absence detection of liquids and solids in all types of process systems, and for run dry protection of positive displacement pumps.

The basic instrument consists of an electronic chassis within a heavy-duty, cast aluminum, weatherproof, explosion-proof housing. (See Figure 1-2 for dimensional drawing.) The housing has a removable lid, which exposes the electronic chassis. The chassis is composed of two circular printed circuit boards, which are held together by a removable system of mechanical spacers, and electrical interconnects. The chassis is easily removed from the instrument housing, allowing convenient replacement should troubleshooting be required.

The housing, with internal electronic chassis, attaches directly to any one of the Princo L600 Series Sensor Flanges. An electrical and mechanical sensor connection is made by simply screwing the housing directly onto the Sensor Flange upper hub NPT fitting.

The electronic chassis performs the RF impedance measurement, and compares the measurement with a set point established by the coarse and fine sensitivity adjustments on the top of the chassis. The set point adjustment is established by making adjustments with actual presence and absence of process material in the pipeline. When the pipeline condition changes relative to the set point, a control relay is switched and the Sensor Status LED changes state.

1.2 Functional Description

The Model L3515 is a new generation of presence/absence detectors that incorporates advanced technology for enhanced performance. The unit is designed to protect progressive cavity or other positive displacement type pumps, plus any other pipeline related devices, which may be damaged by running dry.

The basic function of the device is to detect the absence of process material within a pipeline, and to announce the process material absence in the form of an “alarmed” set of relay contacts. These contacts, typically wired directly to the pump or a PLC, when

“alarmed”, shut down power to the pump, and thus prevent the pump from the damaging effects of running dry.

The Model L3515 can detect the presence or absence of virtually any process material that might flow in a pipeline, from low dielectric constant electrical insulators, to highly conductive electrical conductors. The mechanical nature of these materials can range from thin, low viscosity liquids to thick, viscous materials that severely coat the pipeline and inner surfaces of the Sensor Flange.

The Model L3515 is used in conjunction with a Model L600 Series Sensor Flange. These sensors are available in two distinct types: “Partial Ring” - for conductive process materials, and “Full Ring” - for non-conductive process materials.

The L3515 generates a low level, one MHz signal which is applied between the "active" sensing element on the inside diameter of the flange and the ground reference. With metal pipelines, the pipeline itself is used as the ground reference. With plastic pipelines, a metallic ground flange is required. The presence of the process material between the sensing element and the ground create a change in the RF impedance that is sensed by the electronic circuitry. This signal is amplified and rectified. The resulting DC voltage signal is proportional to the RF impedance. The L3515 electronics compares this signal with a DC level established by the settings of the coarse and fine sensitivity adjustments. When the measurement signal passes above or below the set point, the relay contacts are switched accordingly.

The unit is normally hard-wired at the factory for fail-safe low operation (relays are de-energized when pipeline is empty). Fail-safe high is available upon request.

An enhanced feature of the Model L3515 is it's superior temperature stability. Special electronic circuitry is incorporated into the L3515 that corrects for any changes in the measurement signal due to ambient air temperature influences on the highly sensitive electronic circuits. The result is a highly temperature stable presence/absence detector. The L3515 can be used to reliably detect even the lowest dielectric constant process materials.

1.2.1 Basic Features

- RF Impedance Sensing Technology with Null-Kote™

The L3515 uses RF impedance technology, proven in tens of thousands of applications. With no moving parts, the measurement depends

Section One: Description

solely on its modern, electronic circuitry, ensuring years of dependable operation.

- **Heavy Duty Control Relay**

Two sets of Form C (DPDT) contacts are provided via a six position terminal block (TB1) located on the top printed circuit board of the L3515. The contacts are rated at 5 amps at 115 Vac.

- **Sensor Flange Status Indicator**

The status of the process material at the sensor is indicated by the color of the SENSOR STATUS LED. The two color (red/green) LED is located on the top printed circuit board of the L3515. Red indicates an absence of material in the pipeline; green indicates a presence.

- **Coarse and Fine Sensitivity Adjustments**

Two large diameter, linearly scaled, single-turn potentiometers (SENS C & F) are provided on the top printed circuit board of the L3515. These adjustments are used to establish a repeatable switch point that is calibrated to the given process material application.

- **Low Acting Alarm Action**

A low alarm condition occurs when the process material is removed from the sensor (pipeline empty - absence). The alarm condition is defined as a de-energized control relay.

- **Fail Safe Alarm Action**

The L3515 is in normal, non-alarmed state when it's control relay is energized (pipeline full - presence, LED green). If the L3515 were to lose power, the control relay would de-energize (LED red). Thus a power failure would produce an alarm condition – alerting the operator that a problem exists.

- **Time Delay Adjustment**

The L3515 senses the process material change (presence/absence) instantaneously. However, a delay can be inserted between the instant the instrument senses the change, and the time the control relay correspondingly de-energizes. A single-turn TIME DELAY pot is provided on the top printed circuit board of the L3515. The potentiometer allows an adjustment of 0 to 30 seconds of time delay.

The time delay feature is useful to prevent momentary voids or cavities in the process material flow stream from causing the control relay to continually change state. Note that the SENSOR STATUS LED changes immediately

from green to red, even when a delay is applied. The unit is factory-set for delay in one direction only – from energized state to de-energized.

1.3 Sensor Flange Description

Princo manufactures several types of Sensor Flanges for use with the L3515 and L3545 Presence/Absence Detectors. The electrical, chemical and physical characteristics of the process material determine the best flange for a particular application.

Partial-Ring Flanges (models L632, L642, L652 and L662) are generally used for process materials that are electrically conductive. They may be used for all applications in which the pipe is 75 to 100% full under normal (safe) conditions. They are the mandatory choice for super-conductive materials such as acids, brines, or effluents and for conductive materials that tend to build up a coating on the Sensor Flange. Partial-Ring Flanges have a relatively small area of exposed stainless steel sensing element on the inside diameter of the Flange. This is desirable for conductive materials where the process material creates a virtual "short" between the sensing element and the grounded metal pipeline ground flange.

Full-Ring Flanges (L631, L641, L651 and L661) are generally used for process materials that are electrically non-conductive. They are typically used to define pipe levels from 5 to 100% full. They are not suitable for super-conductive materials such as acids, brines and effluents. They may NOT be used where conductive material builds up on the Flange. Full-Ring Flanges have a stainless steel sensing element that circles the full inside diameter of the Sensor Flange. It provides maximum contact area for non-conductive process materials, which are dependent upon a changing dielectric constant between the sensing element and the grounded metal pipeline or ground flange.

With a Full-Ring Flange, a conductive process material would possibly create a constant contact (indicating constant presence state) between the sensor element and the ground, especially if the flange were mounted in a horizontal section of pipeline. Likewise, a Partial-Ring Flange, when used in a non-conductive application, might not produce a large enough change in RF conductivity to trigger a change of state in the controller.

The standard Sensor Flanges are the L631 (Full-Ring) and the L632 (Partial-Ring). These Flanges are made from 150 lb ASTM size carbon steel flanges, with inner-diameter exposed surfaces of epoxide and 316 stainless steel. They are available in sizes of one to twelve inches. See Figure 1-1 for flange diagrams.

Section One: Description

Other Flange options include: 316 stainless steel flanges with exposed surfaces of 316 stainless steel and Teflon®; and Flanges with Tri-Clamp connectors. Flanges with inner surfaces covered by Teflon® "boots" are available for applications incompatible with stainless steel and epoxide. Refer

to the table in Section Two, Specifications, for a full listing of Sensor Flange models and their specifications. Consult the factory for specific application questions.

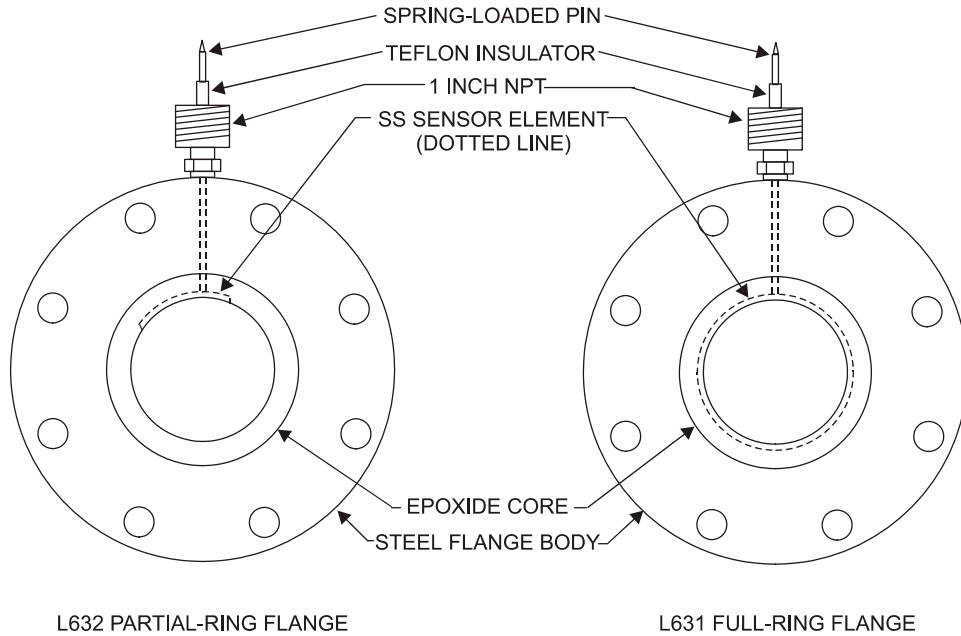

Figure 1-1. Typical L631 and L632 Sensor Flanges

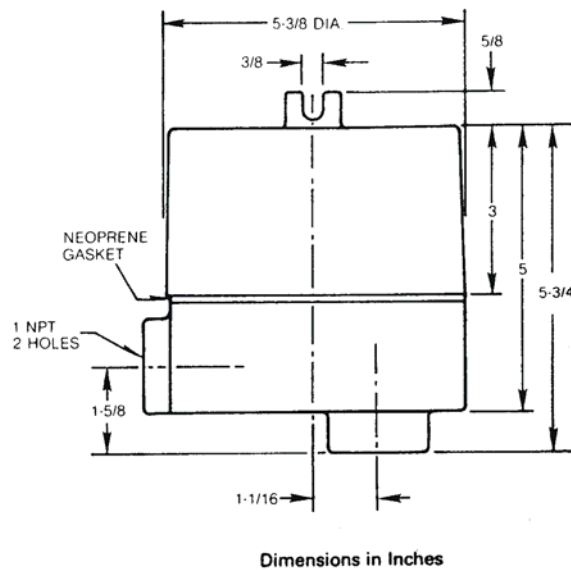

Figure 1-2. L3515 Outline Drawing and Dimensions

2 Specifications

2.1 L3515 Presence Absence Detector

- **TYPE**
Point type (on/off), solid state electronic, high frequency (RF), impedance sensing, Presence/Absence Detector.
- **POWER REQUIREMENTS**
95 to 135 Vac, 50 to 60Hz, 1.3 watts; or 205 to 255 Vac, 1.3 watts; or 12 to 34 Vdc, <1 watt.
- **AMBIENT TEMPERATURE RANGE**
-40 to 150 °F (-40 to 66 °C)
- **SENSITIVITY**
Senses capacitance as low as 0.15pF. Sensitivity may be decreased to approximately 1000pF.
- **TEMPERATURE STABILITY**
Less than 1.0 pF typical (-40 °F to +150 °F).
- **CONTROL RELAY CONTACTS**
Two sets of form C contacts, rated at 5 amperes, 115V ac or 26V dc, resistive load.
(Two sets of form C contacts, rated at 10 amperes, 115V ac or 26V dc, resistive load for units made before January 1, 2008.)
- **ALARM TYPE**
Low Acting: Alarm occurs upon absence of process material (unless otherwise specified).
- **ALARM ACTION**
Fail Safe Alarm: Control relay de-energizes (drops out) upon alarm.
- **STARTUP PUSH-BUTTON**
Overrides normal control function when depressed (start/prime pump). After push-button is released, override continues for a period of time equal to pre-set delay time.
- **DELAY TIME AND DELAY MODE OPTIONS**
Standard delay is adjustable from 0 to 30 seconds. Standard mode is delay turn-on alarm. Consult the factory for other configurations.
- **ELECTRONIC HOUSING**
Heavy-duty, cast aluminum weatherproof housing for the following categories:
Explosion-proof for: Class I, groups C & D; Class II, groups E, F & G.
Weatherproof: NEMA 4

2.2 L600 Series Sensor Flanges

- **STANDARD FLANGE SIZES, MODELS L631 AND L632**
Carbon steel, 150 lb ASTM sizes 1 to 12 inches.
- **DESCRIPTION BY MODEL NUMBER**

Model Number	Sensor Type	Wetted Surfaces	Flange Material	Connection
L631	Full-Ring	Epoxide, 316SS	Carbon Steel	Flanged
L632	Partial-Ring	Epoxide, 316SS	Carbon Steel	Flanged
L641	Full-Ring	Teflon®, 316SS	316SS	Flanged
L642	Partial-Ring	Teflon®, 316SS	316SS	Flanged
L651	Full-Ring	Epoxide, 316SS	Carbon Steel	Tri-Clamp
L652	Partial-Ring	Epoxide, 316SS	Carbon Steel	Tri-Clamp
L661	Full-Ring	Teflon®, 316SS	316SS	Tri-Clamp
L662	Partial-Ring	Teflon®, 316SS	316SS	Tri-Clamp

Section Three: Installation

- PRESSURE / TEMPERATURE RATINGS**

Model Numbers	PSI @ °F
L631*, L632*, L651*, L652*	200 @ 100
	50 @ 150
	0 @ 200
L641, L642, L661, L662	200 @ 100
	100 @ 200
	0 @ 300

*Protect from thermal shock.

- DIMENSIONAL INFORMATION**

Refer L3515 specification sheet at www.pricolevelcontrols.com

Flange Size	1	1-1/2	2	2-1/2	3	4	6	8	10	12
Part No. Suffix	10	15	20	25	30	40	60	80	100	120
Dim. A	1.05	1.61	2.07	2.47	3.07	4.03	6.06	7.98	10.02	12.00
Dim. B	5/8	5/8	11/16	3/4	13/16	7/8	15/16	1-1/16	1-1/8	1-1/8
Dim. C	4-1/4	5	6	7	7-1/2	9	11	13-1/2	16	19
Dim. L651/652	3-7/8	3-7/8	4-1/8	4-1/8	4-1/4	4-7/8	-	-	-	-
L661/662	3-3/4	3-3/4	4	4	4-1/8	4-3/4	-	-	-	-
Dim. F	1-31/64	1-31/64	2-23/64	3-3/64	3-37/64	4-11/16	-	-	-	-
Dim. G	7/8	1-3/8	1-7/8	2-3/8	2-7/8	3-7/8	-	-	-	-
Bolt Circle Dia	3-1/8	3-7/8	4-3/4	5-1/2	6	7-1/2	9-1/2	11-3/4	14-1/4	17
No. of Holes	4	4	4	4	4	8	8	8	12	12
Bolt Hole Dia.	5/8	5/8	3/4	3/4	3/4	7/8	7/8	7/8	1	1

3 Installation

3.1 Inspection

The L3515 Presence/Absence Detector is supplied with one of the Princo L600 Series Sensor Flanges. The L3515 and Sensor Flange are shipped in separate packages.

Carefully remove each package's contents and check each item against the packaging list. Inspect each item for shipping damage. In particular, check the spring-loaded connection pin, located on the threaded hub end of the Sensor Flange (see Figure 1-1). This pin provides the necessary electrical connection from the L3515 chassis bottom printed circuit board, to the active element of the Sensor Flange. Make sure this pin is not missing, bent, jammed, or otherwise damaged. It should be straight, free moving and should extend about 1-1/4" from the surface of the hub. Also, on the L631 and L632 Flanges, check for any cracks between the steel and epoxy surfaces. The surfaces should be mated smoothly with each other with no cracks.

CAUTION!

Care must be exercised when handling the Sensor Flange. Do not allow the spring-loaded pin on the Sensor Flange threaded hub to be accidentally hit or jarred on a hard surface. An accidental blow to this pin may cause poor contact with the active sensing element, on the inner surface of the sensor flange, rendering the sensor inoperable.

Report any such damage immediately to the factory.

3.2 Mounting

3.2.1 Partial-ring Flange (L632, L642, L652, L662) Location

The most common application of L3515 presence-absence technology is for protection of positive displacement pumps for conductive (water-based) applications. Simply put, the flange must be installed in such a position that the fluid will be touching the sensing element of the flange when the pump is to be running and not touching the sensing element when the pump is to be off. Refer to Figure 1-1 for sensing element location. It is preferred that the Sensor Flange be mounted in a vertical pipe segment as close as possible to the inlet side of the pump or other device to be protected.

If the Sensor Flange is mounted in a horizontal pipe segment, it should also be located as close as possible to the inlet side of the pump or other device to be protected. The NPT connection hub on the Sensor

Flange must always be in the 12 o'clock position, as illustrated in Figure 1-1. Tilting the flange orientation to one side or the other risks having the pump turned on when there is only a residual amount of fluid in the pipeline.

The dynamics of flow within a pipeline are often difficult to predict with any certainty. Experience has shown that certain locations may be problematic. These locations include immediately before or after a 90-degree bend (whether in a vertical or horizontal line of flow). These areas are prone in some cases to creating air pockets which turn the pump off, and in other cases to excess buildup of coating which may leave the pump on when it shouldn't be. Some locations in pipelines are likely to have air at the top even when there is steady flow. Princo recommends avoiding locations where this is possible. See Figures 3-2 through 3-7 below as examples of possible problematic locations and recommended locations.

3.2.2 Full-ring Flange (L631, L641, L651, L661) Location

Full-ring sensor flanges are used mainly for non-conductive process materials such as oils. They may safely be mounted in vertical or horizontal sections of pipeline, preferably as close as possible to the pump inlet. They do not have to be mounted at a 12 o'clock orientation. Since the sensing element circles the full inside diameter of the flange, the may be set at any orientation desired. Refer to Figure 1-1 for sensing element location.

3.2.3 Full-faced Gaskets & Flanges

Use a **full-faced type gasket** on each side of the Sensor Flange. Following these instructions will prevent product build-up around the sensing area inside the flange.

NOTE

The Sensor Flange is designed to mate against **full-faced gaskets** and **full-faced pipeline flanges**. These gaskets should have an inside diameter **exactly equal to the inside diameter of the pipeline** in the installation. Mating against raised-face flanges and gaskets could cause cracking and improper sealing of the epoxy inner ring of the Sensor Flange. Improper gaskets may result in leakage of process material inside the flange causing the pump to run dry, as well as up into the electronic housing resulting in damage to the electronics boards.

Section Three: Installation

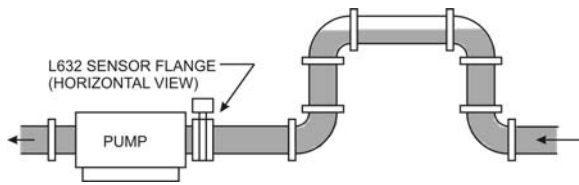

Figure 3-1. Correct Horizontal Installation (Horizontal View)

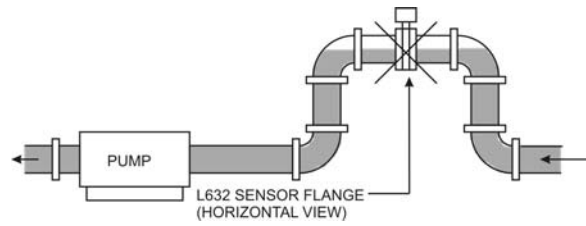

Figure 3-2. Questionable Horizontal Installation (Horizontal View)
Possible air in line

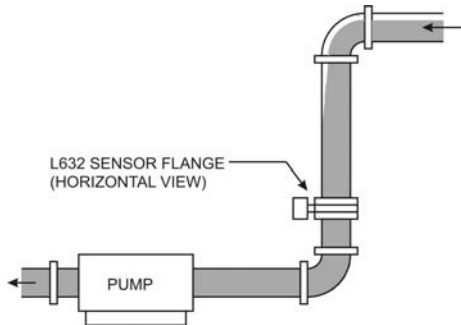

Figure 3-3. Correct Vertical Installation (Horizontal View)

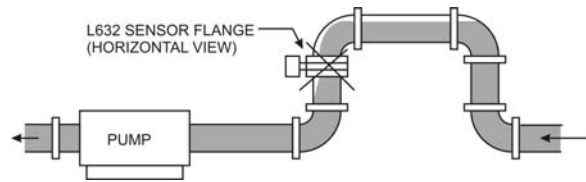

Figure 3-4. Questionable Vertical Installation (Horizontal View)
Possible air pockets near sensing element

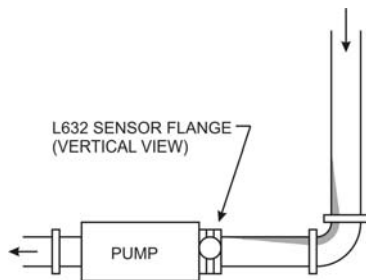

Figure 3-5. Correct Horizontal Installation (Vertical View)

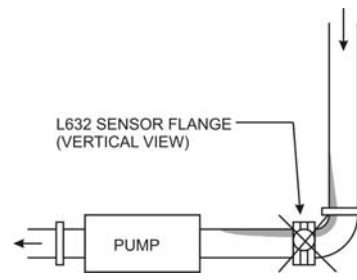

Figure 3-6. Questionable Horizontal Installation (Vertical View)
Possible excessive build-up or air pockets near 90° bend

3.2.4 L3515 Controller Mounting

After mounting the Sensor Flange to the pipeline, screw the L3515 housing onto the Sensor Flange NPT threaded hub. This is all the support it requires.

NOTE

Do not use any type of thread lubricant on the NPT probe mounting threads or the NPT threads that mount the electronic housing. Thread lubricant may cause faulty or improper ground connection. If required, Teflon tape may be used. If Teflon tape is used, the installer should make an electrical continuity check with a hand-held ohmmeter. Continuity should exist between the metal pipeline and the Sensor Head metal housing with less than 1-ohm resistance between these two points. Refer to Figure 3-8 for ground testing points.

Section Three: Installation

3.2.5 Spring-loaded Pin

Make a visual check, through the Sensor Head wiring port, to verify the spring-loaded pin makes contact with the bottom printed circuit board. This may also be verified by loosening the two 8-32 mounting screws that hold the electronic chassis in the housing. The spring-loaded pin action should be felt pushing the chassis upward. If not, it may be stretched out somewhat with a pair of pliers. See Figure 3-8 below. The spring-loaded pin is the electrical connection between the sensing element on the Sensor Flange and the electronic controller. Good contact is critical.

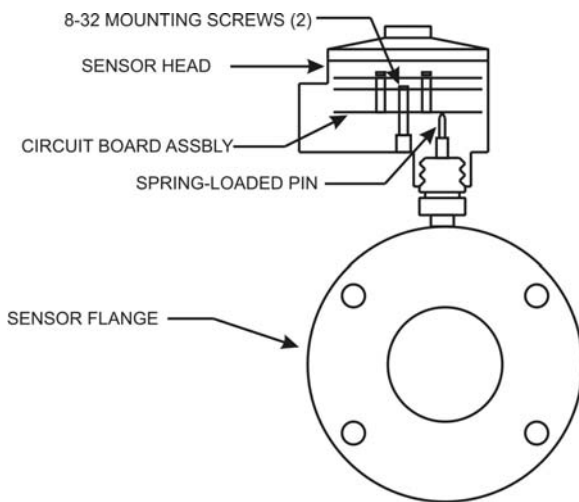

Figure 3-7. Spring-loaded Pin

3.2.6 Grounding

Reliable operation of the L3515 Presence/Absence Detector will only occur through proper installation. The most important installation consideration is a proper sensor ground return.

If the pipeline is metal, the ground return connection is made when the sensor is properly mounted onto the pipeline. To insure proper ground connection, install a ground wire between metal pipe mounting and the ground screw on Sensor Flange as shown in Figure 3-8.

If the vessel is non-metallic (i.e. plastic, or plastic lined), a separate ground return must be provided. The ground return must consist of a separate metal mounting flange, installed into the pipeline, adjacent to the Sensor Flange. A ground wire must be installed between ground screw on Sensor Flange and the ground screw on metal ground flange, as shown in Figure 3-8.

3.2.7 Ground Continuity Test

Refer to figure 3-8 below.

1. Turn L3515 power off.
2. Use ohm meter on lowest scale to check following:
 - point A (two posts) to point B - less than 1 ohm.
 - point B to point C - less than 1 ohm.
 - point C to point D (both ends of metal pipeline) - less than 1 ohm.
 - point C to point E (plastic pipeline only) - less than 1 ohm.

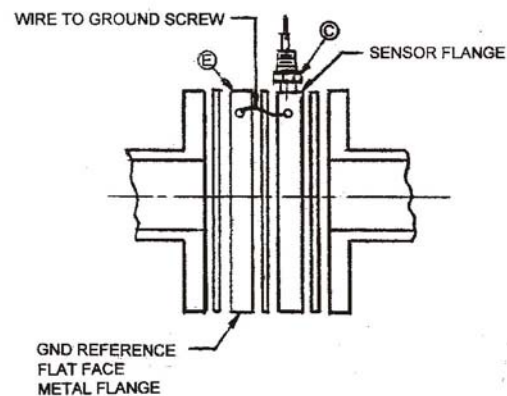
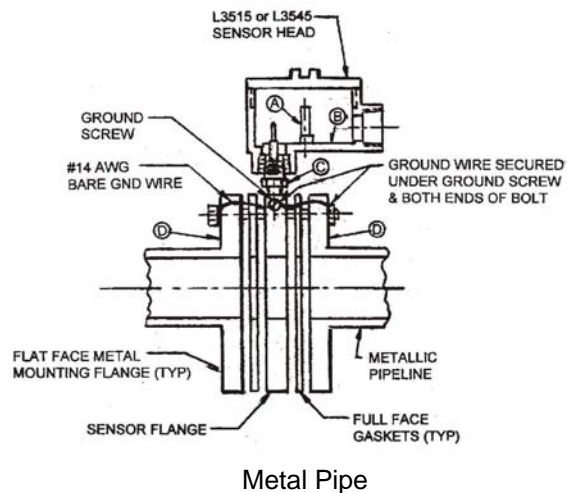

Figure 3-8. L3515 Installation and Ground Checks

Section Three: Installation

3.3 Electrical Connections

Remove the lid of the L3515 electronic housing in preparation for connection of input and output wires. Before drawing wires into the equipment housing, it may be necessary to remove the electronic chassis. To do so, unfasten the two 8-32 mounting screws which are located on either side of the terminal strips. Once screws are unfastened, the chassis may be lifted or removed from the housing. The power and relay contact wires may now be pulled through the 1 inch NPT wiring port.

Connect the 115Vac or 230Vac power line wires: Hot (H), Neutral (N), and Ground (G) respectively, to the right terminal strip (TB2) as shown in Figure 3-9. If the unit requires 24Vdc for power, the terminal strip TB2 is labeled as plus (+), minus (-) and ground (G). Connect 24Vdc power accordingly per Figure 3-10.

Connect the normally open (NO), normally closed (NC) and common (C), relay wires to the left hand terminal strip (TB1) as shown in Figure 3-9 and Figure 3-10, and as required by the specific pump motor control circuit. Most pump control and protection applications use the normally open (NO) contacts to break power to the pump if/when the pipeline runs empty. The equipment installer should keep in mind that all L3515 units are factory set to operate in the Fail Safe LOW mode, unless otherwise specified.

NOTE

The relay contact configuration, shown in Figures 3-9 and 3-10, and labeled on the instrument circuit board, is identified as such with the relay in the de-energized (shelf) state. Fail-safe operation requires relay to be normally in the energized (non-shelf) state. Upon alarm, configured as either HIGH or LOW, the relay then becomes de-energized (shelf state), as per Figure 3-9, 3-10 and TB1 labeling.

Replace the electronic circuit board chassis with the flat side of the printed circuit boards facing the wiring port. Replace mounting screws and tighten.

NOTE

The two 8-32 mounting screws **MUST** be fastened securely. These two screws provide the ground connection to the printed circuit board electronics. If not fastened securely, faulty equipment operation may occur.

Verify that all connections were made correctly.

3.4 Installation in Hazardous Areas

The outline which follows points out some of the major requirements of the NEC's (National Electric Code) Section 501, as it relates to typical level control installations.

WARNING!

The Princo Model L3515 Level Control is not to be considered an explosion-proof instrument. The instrument does not incorporate an enclosure that would allow for the appropriate explosion-proof approval rating (see above Section 2 for NEMA ratings).

For all applications, it is the customer's responsibility to install the required conduit, seals, wiring, etc., which meet national, as well as applicable local and plant safety codes.

For Class 1 locations, rigid metal conduit must be used. At least five full threads of the conduit must be tightly engaged in the enclosure. Conduit seal fittings must also be used. These seal fittings, must be filled with an approved sealing compound and must be installed within 18 inches (or closer) of the enclosure. Conduit seals are also required when the conduit passes from a hazardous area into a non-hazardous area. Water drain seal fittings eliminate or minimize the effect of water that tends to collect in the conduit or enclosure due to condensation.

Approved wire type, such as mineral-insulated wire, is required for use in Division 1 installations. Certain types of metal-clad cable or shielded non-metallic sheathed cable are permitted in Division 2 installations. When multi-conductor cables are used in the conduit, the outer jacket must be cut away in such a manner that allows the sealing compound to surround each insulated wire as well as the jacket.

The preceding information should act as guide to assist the customer/installer in satisfying their responsibility for producing safe installations in hazardous area.

Section Three Installation

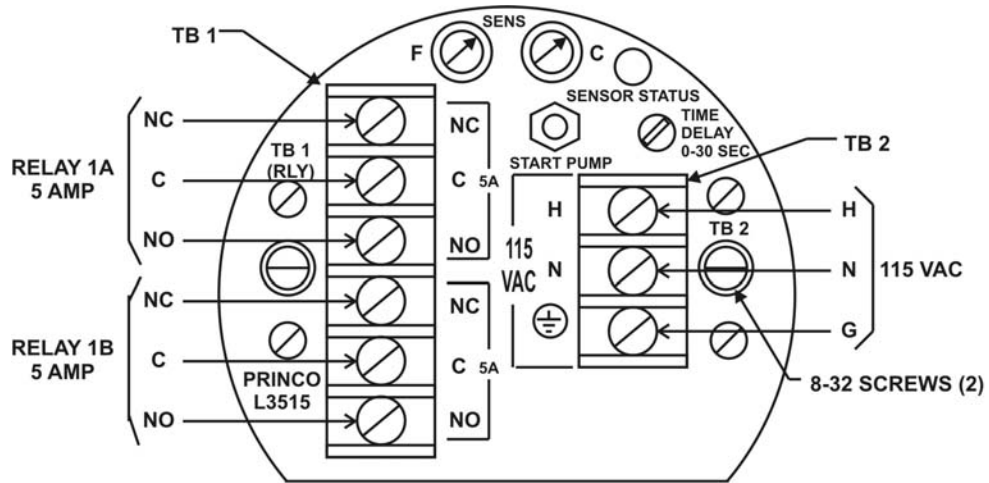

NOTE: Same connections required for 230 Vac units.

Figure 3-9. Electrical Connections (115Vac & 230Vac Units)

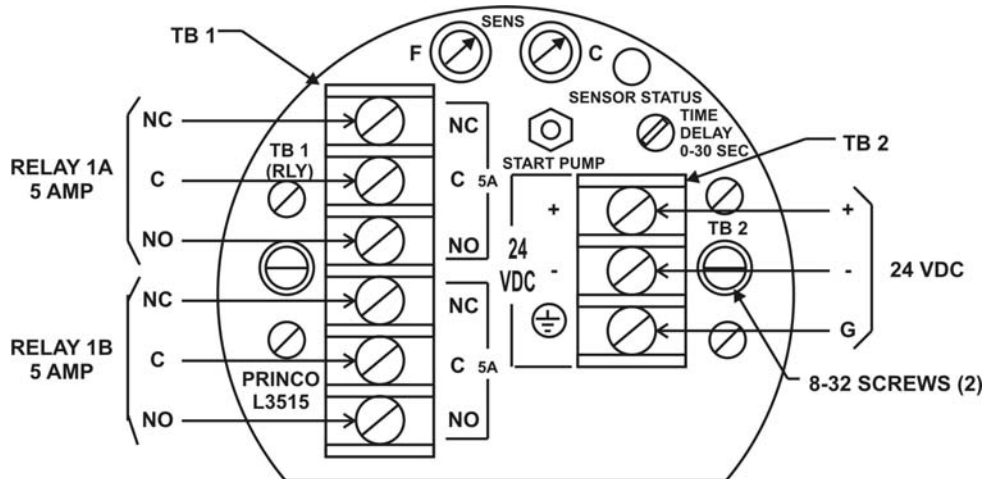

Figure 3-10. Electrical Connections (24Vdc Unit)

Section Four: Adjustments and Operation

4 Adjustments and Operation

4.1 Initial Checkout

1. Refer to Figure 4-1 for L3515 adjustment and indicator locations.

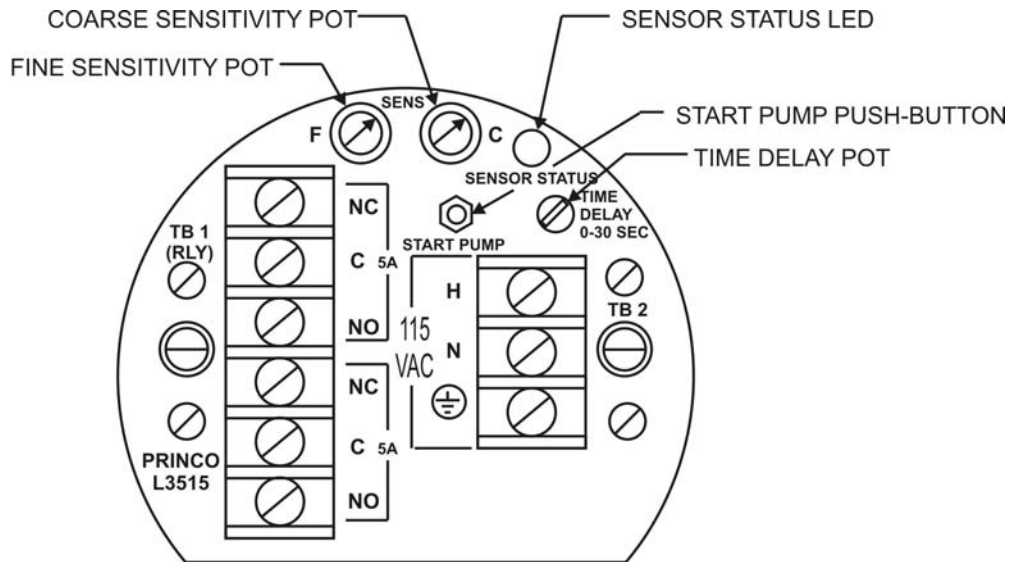

Figure 4-1. L3515 Adjustment and Indicator Locations

4.2 Calibration

The Coarse (C) and Fine (F) sensitivity (SENS) pots must be properly adjusted in order to establish a repeatable switch point for the given process material.

NOTE

Two adjustment procedures are listed below – one for conductive processes and one for non-conductive processes. Water-based processes will generally be conductive. However, conductive processes that leave a thick coating inside the pipeline may approximate the conditions of a non-conductive process and require the use of the non-conductive procedure.

4.2.1 Adjustment Procedure - Conductive Process Materials

- a) Refer to Figure 4-1 for adjustment and indicator locations. Refer to figure 4-2 for a pictorial outline of this procedure.
- b) Allow the unit to warm up (thermally stabilize) for approximately 15 minutes before proceeding with steps c through i below.

2. Install the L3515 Level Controller with Sensor Flange as presented in Section 3 of this manual.
3. Apply power to the unit and allow a 15-minute warm-up time before performing the calibration procedure as outlined below.
4. Perform Section 5.1.1. Basic Electronic Checks.

- c) Preset Coarse (C) and Fine (F) sensitivity (SENS) potentiometers to mid-point positions (12 o'clock).
- d) Turn the TIME DELAY pot to the fully counter-clockwise position (no delay).
- e) Pre-coat the Sensor Flange by filling and then emptying the pipeline with the product that normally flows through the pipeline.
- f) With the pipeline and Sensor Flange completely empty (coated from step e), adjust the Coarse (C) sensitivity such that the SENSOR STATUS LED "just turns" green. Mark the Coarse (C) pot screwdriver slot or mentally note its position.

NOTE

Clockwise rotation increases sensitivity for both Coarse and Fine potentiometers.

- g) Fill the pipeline and Sensor Flange with the product that normally flows through the pipeline.
- h) Adjust the Coarse (C) sensitivity pot counter-clockwise such that the SENSOR STATUS LED "just turns" red. Mark or mentally note position of screwdriver slot.

Section Four: Adjustments and Operation

- i) Adjust the Coarse (C) sensitivity pot until the screwdriver slot is midway between the marks from steps f and h. The SENSOR STATUS LED should now be green (Sensor Flange and pipeline filled with product from step g). If not repeat steps a through i.

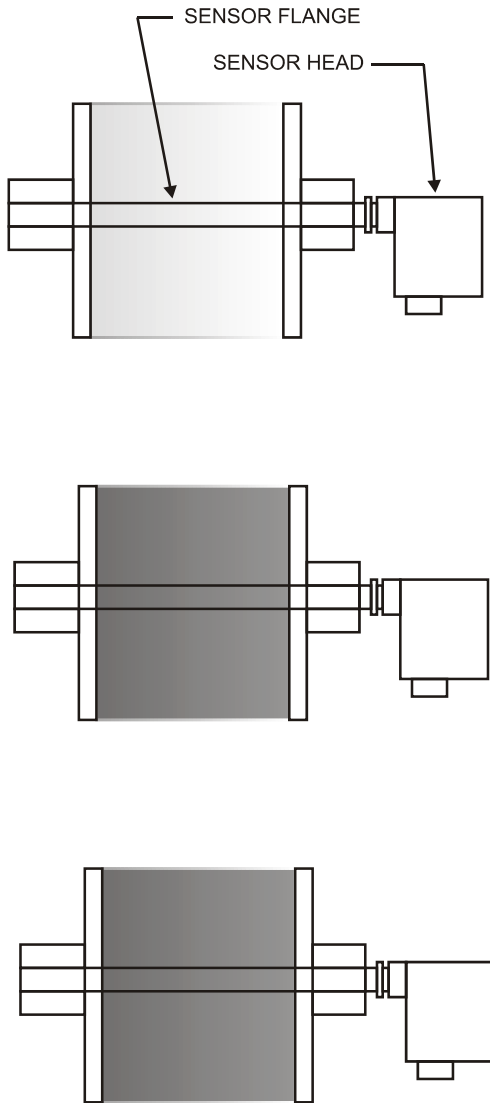

NOTE

A green SENSOR STATUS indicator denotes presence of material in the Sensor Flange, and a red indicator denotes absence of material in the Sensor Flange, when sensitivity potentiometers are properly adjusted.

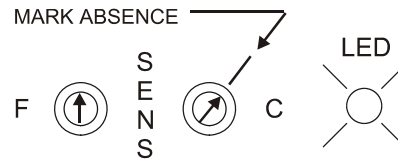

1. Turn TIME DELAY and DEAD BAND (L3545 only) full counter-clockwise, pipeline pre-coated with product.
2. Start with pipeline empty.
3. Adjust F and C to mid-way position (12 o'clock).
4. Slowly adjust C to turn "just green".
5. Mark absence.

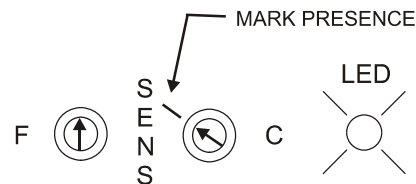

6. Fill pipeline.
7. Slowly adjust C counter-clockwise to turn "just red".
8. Mark presence.

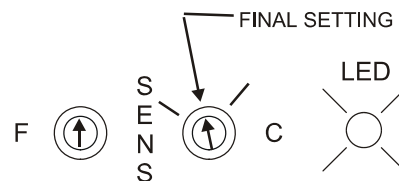

9. Adjust C half way between both marks.
10. LED should be green.
11. LED should turn red when pipeline empty.

Figure 4-2. Conductive Process Calibration Procedure

4.2.2 Adjustment Procedure – Non-conductive (Insulating) Process Materials

- a) Refer to Figure 4-1 for adjustment and indicator locations. Refer to Figure 4-3 for a pictorial outline of this procedure.
- b) Allow the unit to warm up (thermally stabilize) for approximately 15 minutes before proceeding with steps c through j below.
- c) Preset the Fine Sensitivity pot (F) full clockwise and the Coarse Sensitivity pot (C) to the full counter-clockwise position.
- d) Turn the TIME DELAY pot to the fully counter-clockwise position (no delay).

Section Four: Adjustments and Operation

- e) Pre-coat the Sensor Flange by filling and then emptying the pipeline with the product that normally flows through the pipeline.
- f) With the pipeline and Sensor Flange completely empty (coated from step e), adjust the Coarse (C) sensitivity potentiometer such that the SENSOR STATUS LED "just turns" green, and stays. Don't touch the Coarse (C) sensitivity pot again.

NOTE

Clockwise rotation increases sensitivity for both Coarse and Fine potentiometers.

- g) Adjust the Fine (F) sensitivity potentiometer counter-clockwise, such that the SENSOR STATUS LED "just turns" red and then back clockwise until it "just turns" green. Mark the position of the Fine (F) sensitivity pot.
- h) Fill the pipeline and Sensor Flange with the product that normally flows through the pipeline.
- i) Adjust the Fine (F) sensitivity pot counter-clockwise, such that the SENSOR STATUS LED "just turns" red and stays. Mark or mentally note position of screwdriver slot.
- j) Adjust the Fine (F) sensitivity pot until the screwdriver slot is midway between the marks from steps g and i. The SENSOR STATUS LED should now be green (Sensor Flange and pipeline filled with product from step h). If not repeat steps a through j. If this procedure exceeds the span of the Fine (F) pot, use the procedure for conductive materials Section 4.2.1.

NOTE

A green SENSOR STATUS indicator denotes presence of material in the Sensor Flange, and a red indicator denotes absence of material in the Sensor Flange, when sensitivity potentiometers are properly adjusted.

4.3 Alarm Action

The L3515 is in the normal "non-alarmed" state when its control relay is energized. The unit is in the "alarm" state when its internal control relay is de-energized. Hence, if the unit lost power, the internal control relay would de-energize, and an "alarm" condition would occur. This type of "Fail-Safe" operation is based on the fact that most major malfunctions, including a power failure, would cause the control relay to de-energize.

1. Fail-Safe Low Operation (Low Acting Alarm):

The control relay contacts de-energize (shelf state) upon Low Alarm. When process material

absence is detected, a Low Alarm condition occurs, and the relay changes from the normal "non-alarmed" (energized) state to the "alarmed" (de-energized) state. Unless otherwise indicated, the L3515 has been factory set for Fail Safe Low operation. Consult the factory if change to Fail Safe High operation is required.

4.4 Delay Operations and Adjustments

Time delay is useful in preventing control relay "chatter" caused by momentary pockets of air or voids in the product flow stream as it passes through the Sensor Flange. The three types of time delay are as follows: delayed turn-on alarm, delayed turn-off alarm, and delayed turn-on alarm/turn-off alarm.

The L3515 is normally configured at the factory for delayed turn-on alarm mode.

A single turn TIME DELAY pot is provided (see Figure 4-1). Many applications require no time delay. In this case, adjust the TIME DELAY pot to the maximum counter-clockwise direction (zero time delay).

If Time Delay is required, start by adjusting the TIME DELAY pot to approximately 30 percent of its full CW rotation (about 10 seconds). Determine the optimal setting through trial and error.

The maximum standard delay time is 30 seconds full scale. Consult factory for optional delays.

4.5 Start Pump Push-button

The START PUMP push-button is used to start a pump when the pipeline is empty. Pushing the START PUMP push-button overrides the normal Low Alarm condition (energizes relays) and turns on the pump. The pump will stay on as long as the push-button is held. It will also stay on after the push-button is released for the duration of a pre-set Time Delay. Once process material contacts the Sensor Flange sensing element, the pump will remain on because of the normal control action of the system. Action of a remotely wired push-button (see Section 3.3.1.c) is the same as that of the front panel push-button.

Section Four: Adjustments and Operation

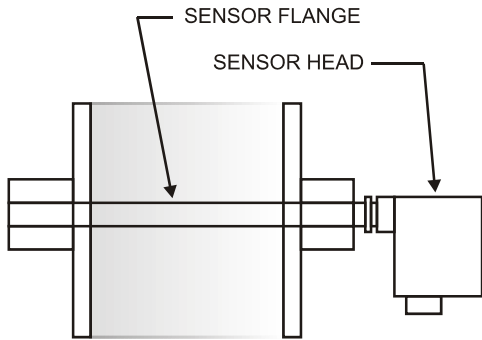

1. Turn TIME DELAY and DEAD BAND (L3545 only) full counter-clockwise, pipeline pre-coated with product.
2. Start with pipeline empty.
3. Adjust F full clockwise and C full counter-clockwise.
4. Slowly adjust C clockwise to turn "just green".

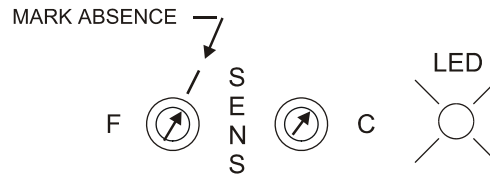
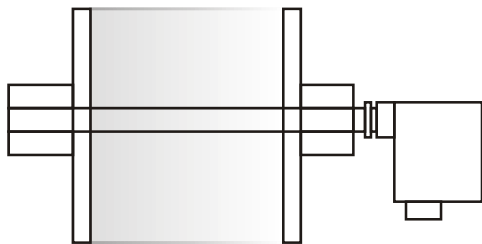

5. Slowly adjust F counter-clockwise to turn "just red", and back clockwise to "just green".
6. Mark absence.

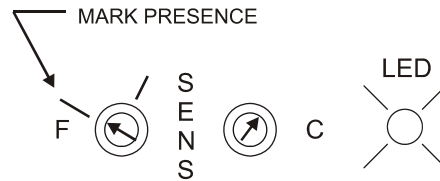
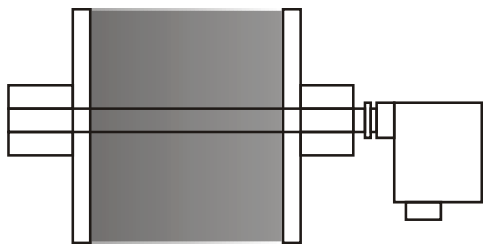

7. Fill pipeline.
8. Slowly adjust F counter-clockwise to turn "just red".
9. Mark presence.

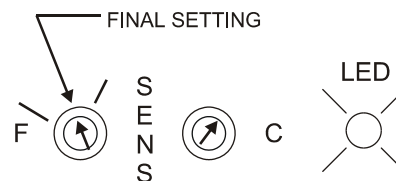
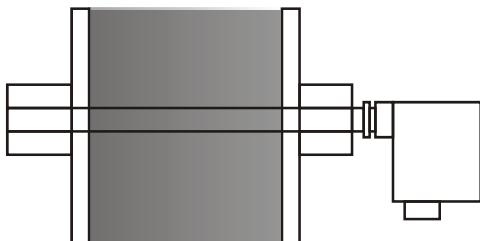

10. Adjust F halfway between both marks.
11. LED should be green.
12. LED should turn red when pipeline empty.

Figure 4-3. Non-Conductive Process Calibration Procedure

5 Equipment Service

5.1 Trouble-Shooting Guide

5.1.1 Basic Electronic Checks

1. Basic Electronic Checks

- ✓ The PROBE STATUS LED should be lit to either red or green at all times. If not, check that proper power is applied to the Power terminals.
- ✓ With both the Coarse (C) and Fine (F) sensitivity potentiometers turned fully clockwise, the PROBE STATUS LED should be green. With both potentiometers turned fully counter-clockwise the LED should be red.
- ✓ The PROBE STATUS LED should switch crisply from green to red or from red to green. It should never hang in between in an orange color.

If the unit fails any of the above checks, return the L3515 electronic chassis to the factory for repair or replacement.

5.1.2 Adjustment Problems

- After performing the adjustment procedure, the unit fails to shut off or on properly.
- ✓ Check ground continuity (refer to Figure 3-9).
- ✓ Check that the spring-loaded pin on the Sensor Flange is making contact with the silver pad on the bottom of the electronic circuit board. Refer to Figure 3-8. The pin normally projects about 1-¼ inches above the NPT fitting on the flange. It may be stretched out further with a pair of pliers without causing damage.
- ✓ Be sure that full and empty pipeline conditions really exist when performing the adjustment procedure. It may be necessary to drain the pipeline to remove residual material before performing the empty adjustment.
- ✓ Check for the presence of process fluid in the Sensor Flange hub and in the housing of the L3515. Leakage of fluid from the pipeline into the hub could produce a constant "presence" condition. If this condition exists, the Sensor Flange is defective and should be returned to the factory for repair or replacement. Likewise, if there is evidence that the electronic circuit boards have been flooded, they should be sent to the factory for testing, and repair as necessary.

NOTE

When performing the adjustment procedure, there should be a noticeable change in the position of the Coarse (C) Sensitivity potentiometer for conductive processes and in the position of the Fine (F) Sensitivity potentiometer for non-conductive processes between the empty and full adjustment points. If there is not, the electronic unit is not sensing any change, probably due to one of the above conditions.

Typically, for conductive processes, the switch point for the Coarse pot for absence will be between 1 and 3 o'clock, and for presence between 9 and 11 o'clock. In other words, when going from absence to presence, the switch point will shift in the counter-clockwise direction.

- Unit switches correctly once or several times and then fails to switch correctly.
- ✓ A progressively thicker coating may be building up inside the pipeline. This would result in a narrower span between the empty and full positions of the Sensitivity potentiometer when performing the adjustment procedure.

Solution: This condition will require performing the adjustment procedure over again when the coating is at its thickest point.

- ✓ There may have been a change in the dielectric constant of the process material. This would change the flow of RF current through the sensor, effectively shifting the switch point.

Solution: RF impedance technology is designed to operate with materials having a constant dielectric constant (therefore, a constant RF conductivity). It may be possible, through trial and error, to find a switch point that works for some changes in dielectric constant; but extreme changes, like oil to water, may be impossible to compensate for. Generally speaking, a unit adjusted for a low dielectric constant material will switch correctly for a higher dielectric constant material or for a conductive material. However, this could be negated by changes in the coating characteristics.

5.2 Getting Help

If your Princo equipment is not functioning properly, and attempts to solve the problem have failed, contact the closest Princo sales representative in your area, or call the factory direct and ask for service assistance. The factory telephone number is 1-800-221-9237.

Section Five: Equipment Service

To assist us in providing an efficient solution to the particular problem, please have the following information available when you call:

1. Instrument model number
2. Probe model number
3. Purchase order number
4. Date of purchase order
5. Process material being monitored
6. Detailed description of the problem

If your equipment problem cannot be resolved over the phone, then it may be necessary to return the equipment for checkout/repair.

Do not return equipment without first contacting the factory for a Return Material Authorization number (RMA #).

Any equipment that is returned **MUST** include the following information in addition to the list above.

7. RMA number
8. Person to contact at your company
9. Return (ship to) address

Princo level instruments are covered by a 10-year limited warranty. You will not be charged if it is determined that the problem is covered under warranty. Please return your equipment with freight charges prepaid. If repair is covered under warranty, Princo will pay return freight charges.

If telephone assistance or equipment return is not a practical solution to the problem, then it may be necessary for field assistance. Trained field service technicians are available from the factory on a time/expense basis to assist in these instances.

5.3 Warranty Statement

All Princo level control instruments are backed by a 10-year warranty. Princo will repair or replace, at its option, any instrument that fails under normal use for up to 10 years after purchase.